

Shop System™ Powder Station Specifications

The Shop System™ Powder Station is used to separate printed parts from the surrounding loose powder in the build box and recycle the loose powder for reuse. Powder is removed using brushes and a hand-held air pick, with negative pressure used to confine loose powder to inside the powder station chamber. An integrated powder recovery system captures, doses, and sieves loose powder, depositing it in a powder mixing keg used to blend the recycled powder with fresh powder for future prints.

PERFORMANCE	Integrated powder capture, dosing, sieving & recovery system	
	Negative pressure system with dust recovery for powder control ¹	
	Air pick for fine depowdering	
PHYSICAL	Dimensions (H x W x D)	1600 x 1200 x 700 mm (63.0 x 47.2 x 27.6 in)
	Weight (without powder)	230 Kg (507 lb)
	Power requirements	100-130V, 4.4 A. 220-240V, 1.9 A. 50/60 Hz, 0.34 kW

DIMENSIONS

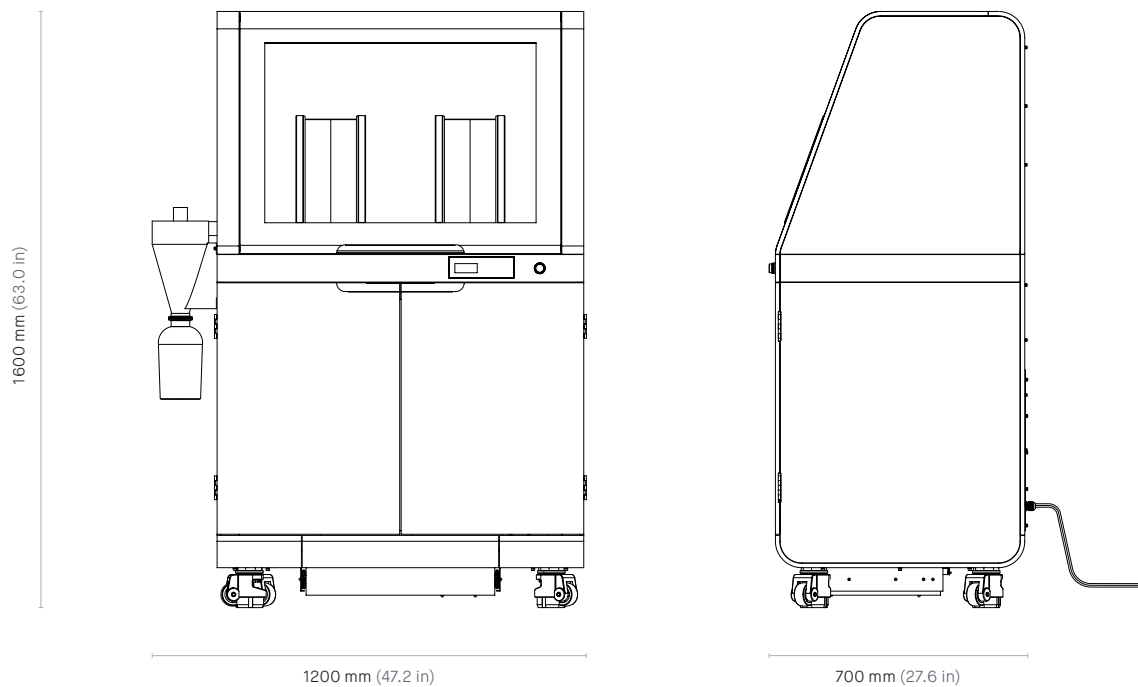

1. Requires compatible vacuum. Available for purchase through Desktop Metal as part of the Shop System™ solution